

MALE END VIEW

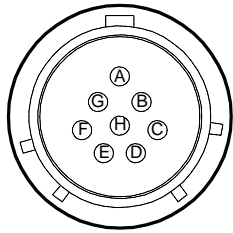

- A = BLACK
- B = WHITE
- C = RED
- D = GREEN/YELLOW
- E = ORANGE
- F = BLUE
- G = WHITE/BLACK
- H = RED/BLACK

CONNECTOR
 TYPE/STYLE/CLASS - MS 3111 M
 SHELL SIZE - 16
 INSERT ARRANGEMENT - 8P

SPECIFICATIONS

CONTACT CARRIER MATERIAL	NEOPRENE
MOLDED HEAD MATERIAL/COLOR	PVC/BLACK
CONTACT MATERIAL/PLATING	COPPER ALLOY/SILVER
COUPLING NUT MATERIAL/PLATING	ALUMINUM ALLOY/OLIVE DRAB CHROMATE
MOLD SLEEVE	ALUMINUM/BLACK ANODIZED
RATED CURRENT [A]	7.0 A
RATED VOLTAGE [V]	300 V
OUTER JACKET MATERIAL/COLOR	PVC/BLACK
CONDUCTOR INSULATION MATERIAL	PVC
NUMBER OF CONDUCTORS	8x16 AWG
TEMPERATURE RATING	-40°C to +105°C (-40°F to +221°F)
PROTECTION CLASS	MEETS NEMA 1,3,4,6P AND IEC IP67,IP68
CONNECTOR TYPE	MIL-DTL-26482

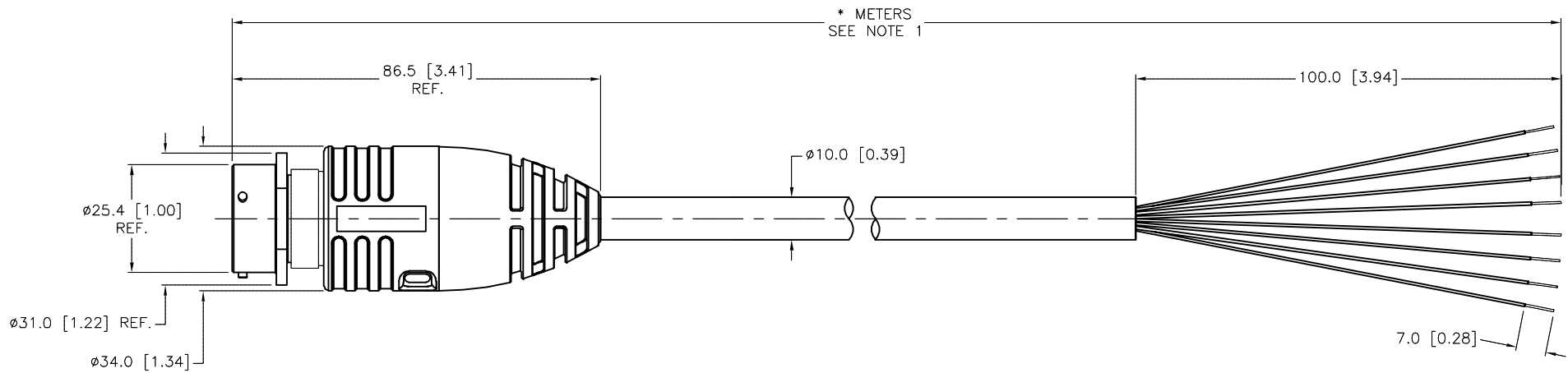

CABLE LENGTH	TOLERANCE*
ALL LENGTHS	+ 4% (OR 50mm) OF LENGTH - 0% (OR 0mm) OF LENGTH WHICHEVER IS GREATER
STRIP LENGTH	TOLERANCE*
0-7mm	±0.5mm
8-29mm	±1.0mm
30-49mm	±2.0mm
50-69mm	±3.0mm
70-100mm	±4.0mm
OVER 100mm	±5.0mm

* UNLESS OTHERWISE SPECIFIED

NOTES:

1. "*" INDICATES CABLE LENGTH IN METERS. CONTACT TURCK TO ORDER SPECIFIC LENGTH.

SOURCE DRAWING - FOR REFERENCE ONLY

RELATED DOCUMENTS 1. 2. 3. 4.	3RD ANGLE PROJECTION 	THIS DRAWING IS CONFIDENTIAL AND THE PROPERTY OF TURCK INC. USE OF THIS DOCUMENT WITHOUT WRITTEN PERMISSION IS PROHIBITED.		3000 CAMPUS DRIVE MINNEAPOLIS, MN 55441 1-800-544-7769 (763) 553-7300 (763) 553-0708 fax www.turck.us		
		MATERIAL	DRFT KMY	DATE 12/18/12	DESCRIPTION MS 3111M-16-8P-1625-*	
		SEE SPECIFICATIONS	APVD E.S.	SCALE 1=1.5		
		FINISH	UNIT OF MEASUREMENT MILLIMETER [INCH]		IDENTIFICATION NO.	REV C
SEE SPECIFICATIONS	CONTACT TURCK FOR MORE INFORMATION	DO NOT SCALE THIS DRAWING		FILE: 777031636	SHEET 1 OF 1	

C	UPDATE CONDUCTOR COLOR	NF	04/05/18	60473
REV	DESCRIPTION	BY	DATE	ECO NO.